

Fuses and MOSFETS and Brakes...Oh My!

by Jeff Goldberg
 JayGee Racing
www.jaygeeracing.com

© 2009 Jeff Goldberg

In the quest to provide racers with more powerful brakes, leading slot car controller manufacturers have been hard at work reducing the already low resistance of their braking circuits. First generation electronic controllers used high wattage potentiometers and expensive power rheostats to control braking current. Later generations made the transition to MOSFET braking, eliminating the resistance of the wire run to the handle, the trigger brake contact resistance and end point resistance of the potentiometer/power rheostat from the brake circuit. It's now gotten to the point that the resistance of the components used to protect the brake make up a significant portion of the total resistance in the brake circuit.

This article compares the resistances of components typically used in slot car controller brake protection circuits, the advantages/disadvantages of using each component type, and describes a new brake circuit protection technology that combines the advantages of components in use today with none of their disadvantages.

The two most common components used to protect brake circuits are automotive fuses and positive temperature coefficient thermistors (PTCs).



ATO automotive fuses

10-Amp ATO automotive fuses are typically used to protect the brake pots in some first generation electronic controllers. As the Littelfuse datasheet resistance chart shows, the resistance of a 10-amp ATO fuse is a very respectable 7.7 milliohms.

Part Number Artikel-Nr.	Current Rating Nennstrom	Housing Color Kennfarbe	Typ. Voltage Drop Typ. Spannungsfall	Cold Resistance Kaltwiderstand	I ² t
0257001_	1 A	Black	176 mV	123 mΩ	0.4 A²s
0257002_	2 A	Grey	141 mV	53.5 mΩ	1.4 A²s
0257003_	3 A	Purple	137 mV	31.1 mΩ	7.4 A²s
0257004_	4 A	Pink	136 mV	22.8 mΩ	14 A²s
0257005_	5 A	Brown	128 mV	17.85 mΩ	26 A²s
025707.5_	7.5 A	Dark Brown	116 mV	10.91 mΩ	60 A²s
0257010_	10 A	Red	109 mV	7.70 mΩ	115 A²s
0257015_	15 A	Blue	102 mV	4.80 mΩ	340 A²s
0257020_	20 A	Yellow	98 mV	3.38 mΩ	520 A²s
0257025_	25 A	White	92 mV	2.52 mΩ	1060 A²s
0257030_	30 A	Green	84 mV	1.97 mΩ	1510 A²s
0257035_	35 A	Light Blue	87 mV	1.61 mΩ	2260 A²s
0257040_	40 A	Orange	96 mV	1.44 mΩ	3310 A²s

Littelfuse ATO Automotive Datasheet

While the ATO fuse has the performance advantage of very low resistance, it's a one-time blow device; the user must scramble to replace the fuse if it blows at the start of a race. That's why some controller manufacturers turned to PTCs for brake circuit protection.

PTCs are known in the slot car industry as resettable fuses. A PTC is a device whose resistance is designed to increase with a rise in temperature, either in the air surrounding the PTC or due to excessive current flow through the PTC itself. They are used to protect both conventional potentiometer controlled brakes and MOSFET brakes. The two types of PTCs shown below are representative of the devices used in some popular electronic controllers.



Strap PTC

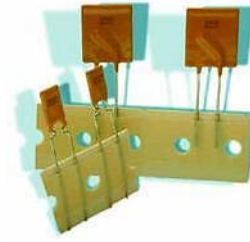

Through-Hole Mounted PTC

A PTC contains fine particles of conductive material suspended in a non-conductive polymer material. As the PTC heats up, either due to ambient temperature rise or excessive current, the non-conductive polymer heats up and expands. The conductive particles move apart, causing the resistance to rise. Eventually, they move far enough apart to cut off all current flow. When the fault causing the excessive current is removed, the polymer shrinks, the conductive particles begin to move closer together and current flow resumes.

While they have the advantage of being automatically resettable, PTCs have a higher resistance than fuses. Not only is their initial resistance higher than a fuse before they blow for the first time, their resistance increases even further after they reset themselves.

Shown below is the datasheet for the LRP200F strap PTC used in the earlier generation JayGee Racing Linear 100 controller to protect its standard and pro brake pots.

Table B3 Electrical Characteristics for Strap Battery Devices ... Cont'd

Part Number	I_H (A)	I_T (A)	V_{MAX} (V _{Dc})	I_{MAX} (A)	P_D Typ (W)	Max. Time-to-trip (s)		R_{MIN} (Ω)	R_{Typ} (Ω)	R_{MAX} (Ω)	$R_{Tripped Typ}$ (Ω)	R_{1MAX} (Ω)	Figure for Dimensions
SRP													
SRP120F	1.20	2.7	15	100	0.8	6.00	5.0	0.085	0.123	0.160	0.170	0.220	B7
SRP120LF	1.20	2.7	15	100	0.8	6.00	5.0	0.085	0.123	0.160	0.170	0.220	B7
SRP120SF	1.20	2.7	15	100	0.8	6.00	5.0	0.085	0.123	0.160	0.170	0.220	B13
SRP175F	1.75	3.8	15	100	0.9	8.75	5.0	0.050	0.070	0.090	0.093	0.120	B7
SRP175LF	1.75	3.8	15	100	0.9	8.75	5.0	0.050	0.070	0.090	0.093	0.120	B7
SRP175SF	1.75	3.8	15	100	0.9	8.75	5.0	0.050	0.070	0.090	0.093	0.120	B13
SRP175SSF	1.75	3.8	15	100	0.9	8.75	5.0	0.050	0.070	0.090	0.093	0.120	B14
SRP200F	2.00	4.4	30	100	1.6	10.00	4.0	0.030	0.045	0.060	0.075	0.100	B7
SRP350F	3.50	6.3	30	100	1.9	20.00	3.0	0.017	0.024	0.031	0.040	0.050	B7
SRP420F	4.20	7.6	30	100	2.2	20.00	6.0	0.012	0.018	0.024	0.030	0.040	B7

Notes:

- I_H : Hold current: maximum current device will pass without interruption in 20°C still air unless otherwise specified.
- I_T : Trip current: minimum current that will switch the device from low resistance to high resistance in 20°C still air unless otherwise specified.
- V_{MAX} : Maximum voltage device can withstand without damage at rated current.
- I_{MAX} : Maximum fault current device can withstand without damage at rated voltage.
- P_D : Power dissipated from device when in the tripped state in 20°C still air unless otherwise specified.
- R_{MIN} : Minimum resistance of device as supplied at 20°C unless otherwise specified.
- R_{Typ} : Typical resistance of device as supplied at 20°C unless otherwise specified.
- $R_{Tripped Typ}$: Typical resistance, measured at 20°C unless otherwise specified, of device one hour after being tripped the first time.
- R_{MAX} : Maximum resistance of device as supplied at 20°C unless otherwise specified.

According to R_{TYP} , the SRP200F will typically have a resistance of 45 milliohms at room temperature, more than seven times the resistance of a 10-amp automotive fuse. But this resistance increases after tripping. Notice from reading the device notes that one hour after tripping, $R_{Tripped\ TYP}$ specifies that the device resistance still hasn't returned to its former state...it's typically 75 milliohms and may even be as high as 100 milliohms!

PTCs are more convenient than fuses because they automatically reset themselves, but they have a higher resistance than fuses. What of there were another circuit protection technology that could combine the best attributes of both PTCs and fuses?

An increasingly popular circuit protection technology used in the latest industrial motor drive circuits is *current sense* technology, combined with reverse polarity protection. Current sensing protection circuits measure the amount of current drawn by the motor by monitoring the voltage drop across a very small value resistor in series with the load. When the voltage drop rises above a pre-determined value the MOSFET driving the load is shut off, usually within microseconds. The control circuit can be designed to automatically reset itself and turn the MOSFET back on after the fault is removed.

While the idea of deliberately introducing resistance into a brake or motor circuit goes against the instincts of slot car racers, specialized current sense resistors are readily available in resistance values as low as 1 to 5 milliohms, as low or lower than the fuses they are replacing.

When people think of choosing devices to provide polarity protection, they typically think of using a diode. However, that approach introduces a significant voltage drop when the diode is conducting in the forward direction, unacceptable in a slot car controller. Rather than use a diode, a reverse wired MOSFET can be used instead. It blocks reverse current flow just like a diode, but when the device is connected to power correctly, the MOSFET is turned on and its on-state resistance drops to just a few milliohms...as low as 3 milliohms or lower, depending on the MOSFET chosen.

The Linear 200 PWM MOSFET transistor module schematic is used to illustrate these points.

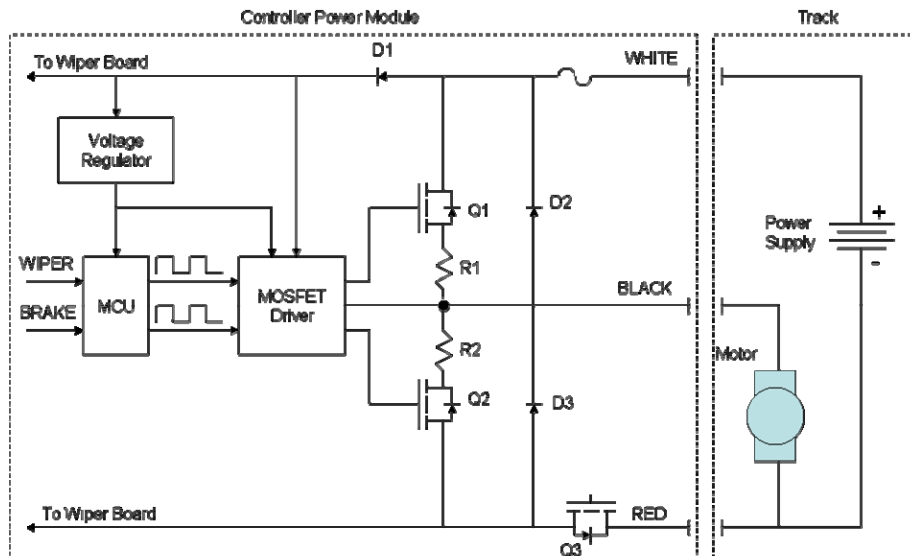

Linear 200 PWM Module Schematic

The brake protection circuit consists of reverse wired MOSFET Q3 and current sense resistor R2 and is identical to the circuit used in the Linear 200 Pro 40. When wired in this fashion, Q3 behaves as a "perfect diode", blocking current flow if the controller's brake line is connected to

track WHITE but introducing no voltage drop when the brake line is properly connected. The MOSFET driver monitors the current flowing through R2, whose resistance is less than that of a 10-amp automotive blade fuse and much lower than the PTC fuses used in other brands of controllers. If the current exceeds a predetermined amount, as would occur if the controller's black line were to touch track WHITE, the MOSFET driver would shut the MOSFET off before it is damaged. An automatic retry built into the MOSFET driver circuit enables the brakes to begin working once the controller is properly wired.

The *total* resistance of all the components (R2, Q2, Q3) used in the Linear 200 Pro 40's brake circuit is less than 8 milliohms, including the resistance of the brake MOSFET itself...comparable to the resistance of a 10-amp fuse alone, let alone the rest of the components used in a conventional electronic controller's brake circuit. This circuit provides the powerful braking that the Linear 200 has become known for, while proving to be very reliable without any component failures on the board in over 18 months of production. The total resistance of the Linear 200 PWM MOSFET module's brake circuit components is a bit higher, 17 milliohms, due to the higher voltage MOSFETs used in that design.

This circuit protection approach combines the best attributes of fuses and PTCs with none of their disadvantages. The resistance of the circuit protection components is comparable to that of an ATO fuse while providing the convenience normally associated with PTCs.